

CONCRETE COVER (OPTIONAL)
1" = 1'-0"

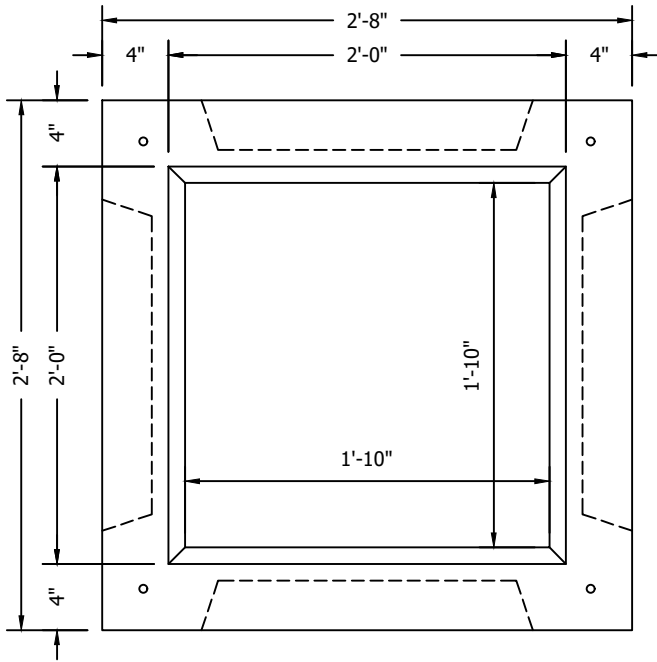

RISER
1" = 1'-0"



PLAN
1" = 1'-0"

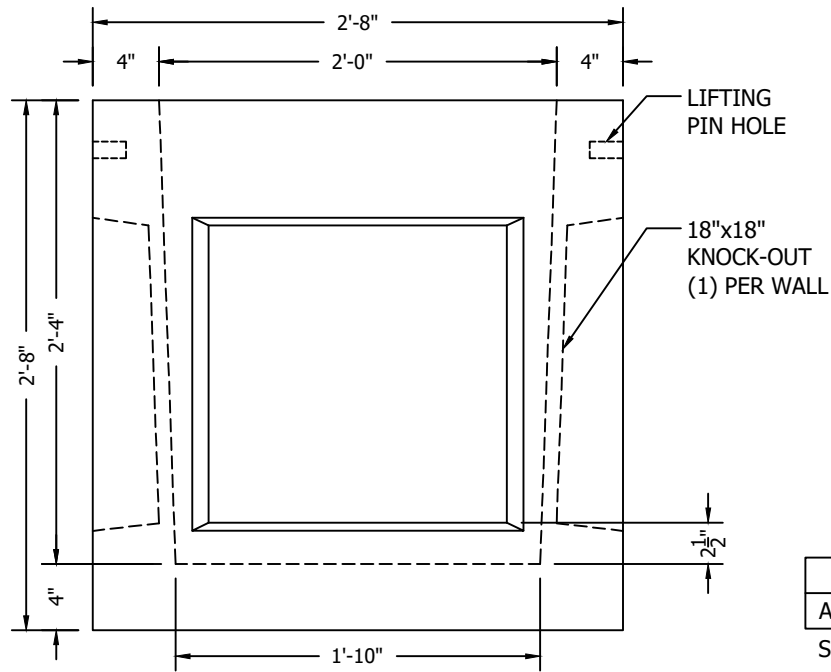

ELEVATION
1" = 1'-0"

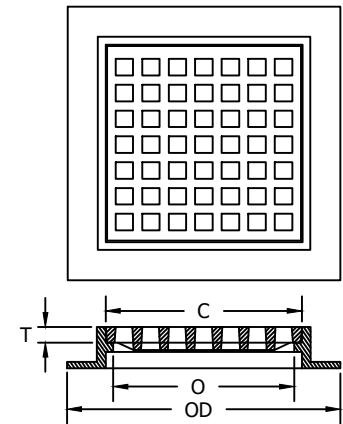

MODEL	C	O	OD	H	T
ASQ24244SH	24X24	22X22	32X32	4	1 1/2

SEE NOTES

FRAME & GRATE
1" = 1'-0"

NOTES:

- 1) CONCRETE TO TEST 5,000 PSI AT 28 DAYS.
- 2) REINFORCING STEEL PER ASTM A615, #4 REBAR.
- 3) LOAD RATING: FOR A.A.S.H.T.O. & HS 20-44 HIGHWAY LOADING.
- 4) ALTERNATE FRAME AND COVER/GRATE PATTERNS AVAILABLE UPON REQUEST.
- 5) RISER HEIGHT OPTIONS INCLUDE 6" (SHOWN), 12", 18" AND 24".

WEIGHT
1,725 POUNDS



276 Clove Road
Salisbury Mills, New York, 12577
www.arconcrete.com
845-562-0640

24" x 24" KNOCK-OUT CATCH BASIN	DATE: 2/15/2021
	REV.: ---
CONTRACTOR: ---	DWN.BY: A&R LLC
	DWG. NO.: 24X24KOCB